



# MxL7080/MxL76500 Power Management Solution for MaxLinear's AnyWAN™ URX800/600 Series and PUMA™ 8 DOCSIS 4.0 SoCs



## WHITE PAPER

### Authors:

**Rex Lee**  
Sr. Principal Platform HW Engineer

**Dat Dang**  
Applications Engineering Manager

**Julio Song**  
Director of IMM Marketing,  
Power Management

### Introduction

In today's rapidly evolving digital landscape, reliable and flexible power solutions are essential across a wide range of embedded, consumer, and industrial applications.

Maxlinear's power sequencing and point-of-load (PoLs) are an essential part of any design, especially in complex systems that utilize multiple power rails. High-performance processing devices such as ASICs, FPGAs, PLDs, DSPs, and microcontrollers require multiple voltage rails to power internal circuitry, such as the core, memory, and I/O. These types of applications demand very specific voltage rail power-up and power-down sequencing and supervision to achieve reliable operation, better efficiency, and overall system health. The combination of power sequencing and power devices are engineered to meet the demands of space-constrained environments while delivering robust functionality and seamless system integration.

The MxL7080/MxL76500 power solution can be integrated with specific power rails, providing an efficient and scalable architecture for platforms such as Intel Atom. Additionally, the MxL7080/MxL76500 solution can complement systems running AI and ML workloads powered by ARM or AMD processors, offering high-performance power delivery with optimized thermal and electrical efficiency.

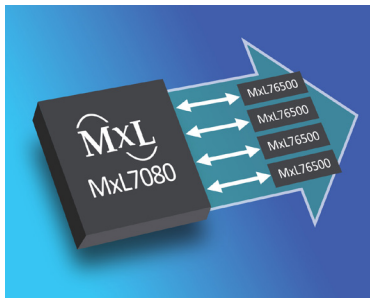

### Product Overview

The MxL7080/MxL76500 intelligent power manager solution supports the Maxlinear's AnyWAN™ SoC URX800/600 series and PUMA™ 8 DOCSIS 4.0 SoC, using a reference-based multi-phase power architecture consisting of a controller and four Smart Regulating Stage (SRS) as shown in Figure 1.

The MxL7080 controller is responsible for start-up, power sequencing, fault monitoring, and dynamic voltage scaling (DVS) via four DAC outputs to control the MxL76500. These outputs provide precise voltage control from 0.6V to 1V in 5mV steps, ensuring precise power delivery to the SoC.

The MxL76500 is a 5A Smart Regulating Stage (SRS) with a wide input range from 5V to 17V. Its constant on-time (COT) architecture ensures a fast transient response and supports 500kHz or 1MHz switching frequency, offering a high efficiency and compact footprint.

The MxL76500 SRS offers fast, automatic voltage control and built-in protection. It instantly adapts to changes and faults, making the system more responsive, reliable, and ready to handle demanding conditions.

The MxL7080 and MxL76500 provide precise, reliable, and thermally efficient power management in a modular, MxL7080 in a 4mm × 4mm 32-pin QFN and MxL76500 in a 2mm × 2mm 10-pin QFN, ideal for high performance broadband and networking applications.

### Features

- Wide  $V_{IN}$  range: 5V to 17V
- Four output rails
- Dynamic voltage scaling (DVS) with 5mV resolution
- 1% typical output accuracy
- Power-up and power-down sequencing
- DAC short-circuit detection

### Applications

- DOCSIS 4.0 modems or gateway
- Fiber optics home gateway unit (HGU)
- Ethernet Wi-Fi home router
- DSL/G.fast home gateway
- Fixed wireless access (FWA) home gateway

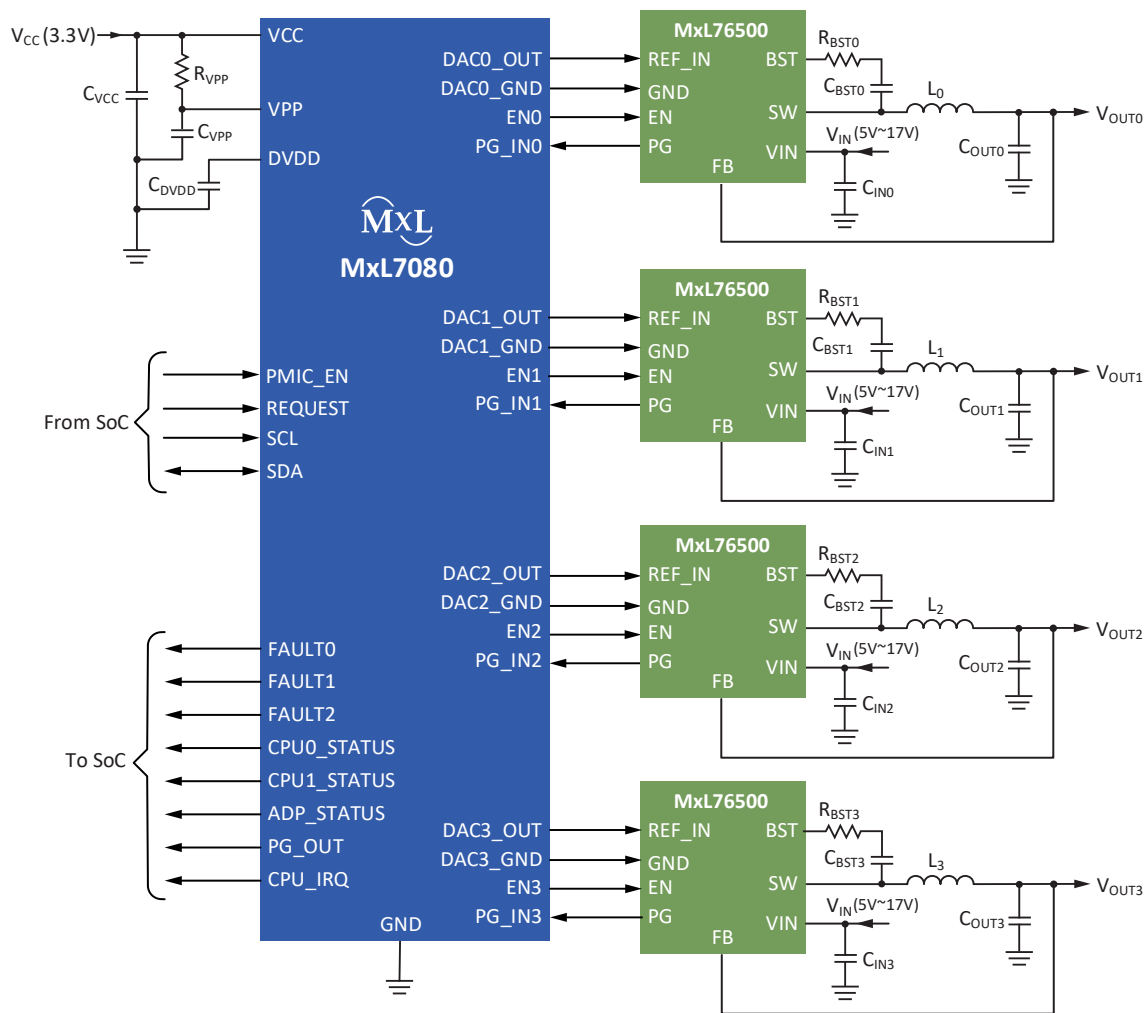

Figure 1: MxL7080/MxL76500 Typical Application Circuit

## Technical Specifications

### MxL7080/MxL76500 Power Manager

- Wide  $V_{IN}$  range: 5V to 17V
- Four output rails
- Output ranges from 0.6V to 1.2V with 5mV resolution
- DVS support by four outputs
- Selectable DVS ramp rates
- 1% typical output accuracy
- Each output current up to 5A
- Switching frequency: 500kHz or 1MHz
- Fast load transient response
- Interface: I<sup>2</sup>C + sideband signals
- Power good (PG) indicator
- Protections:
  - Over-current protection (OCP)
  - Under-voltage protection (UVP)
  - Over-voltage protection (OVP)
  - DAC short-circuit detection
  - Thermal shutdown (TSD)
  - Input under-voltage lockout (UVLO)
- Power-up and power-down sequencing
- Automatic fault recovery with programmable retry count
- Package:
  - MxL7080: 4mm × 4mm, 32-pin QFN
  - MxL76500: 2mm × 2mm, 10-pin QFN

### Use Case Scenarios

The MxL7080/MxL76500 power management solution is purposely built for MaxLinear's AnyWAN™ URX800/600 series and PUMA™ 8 DOCSIS 4.0 SoCs. It fully meets the core power requirements of the SoC, including four critical rails (CPU0, CPU1, ADP, and ROC), as well as additional system rails such as DDR, 1V8, and 3V3.

This solution is ideal for powering the four core rails, delivering up to 5A per rail with excellent thermal performance. With a wide input voltage range (from 5V to 17V), it efficiently converts a standard 12V power input down to SoC-level voltages, minimizing conversion losses.

The reference-based multi-phase architecture allows for flexible PCB layout. Each MxL76500 SRS can be placed close to its respective SoC rail, reducing power loss and improving transient response.

In contrast, typical monolithic PMIC from other competitors provides only one output rail up to 3.2A, or 4A in two-phase mode, which may not be sufficient for high-performance SoCs. Their solution also faces thermal limitations and requires an additional conversion stage due to its limited input range (from 2.85V to 5.5V), increasing both power loss and system cost. Furthermore, the fixed layout of monolithic PMICs restricts placement flexibility, making it difficult to optimize power delivery to each SoC rail.

In addition to the four core rails, MaxLinear also provides solutions for DDR, 1.8V, and 3.3V system rails, enabling complete and efficient power architecture for the entire SoC platform.

The following figure shows the diagram of the MxL7080/MxL76500 solution.

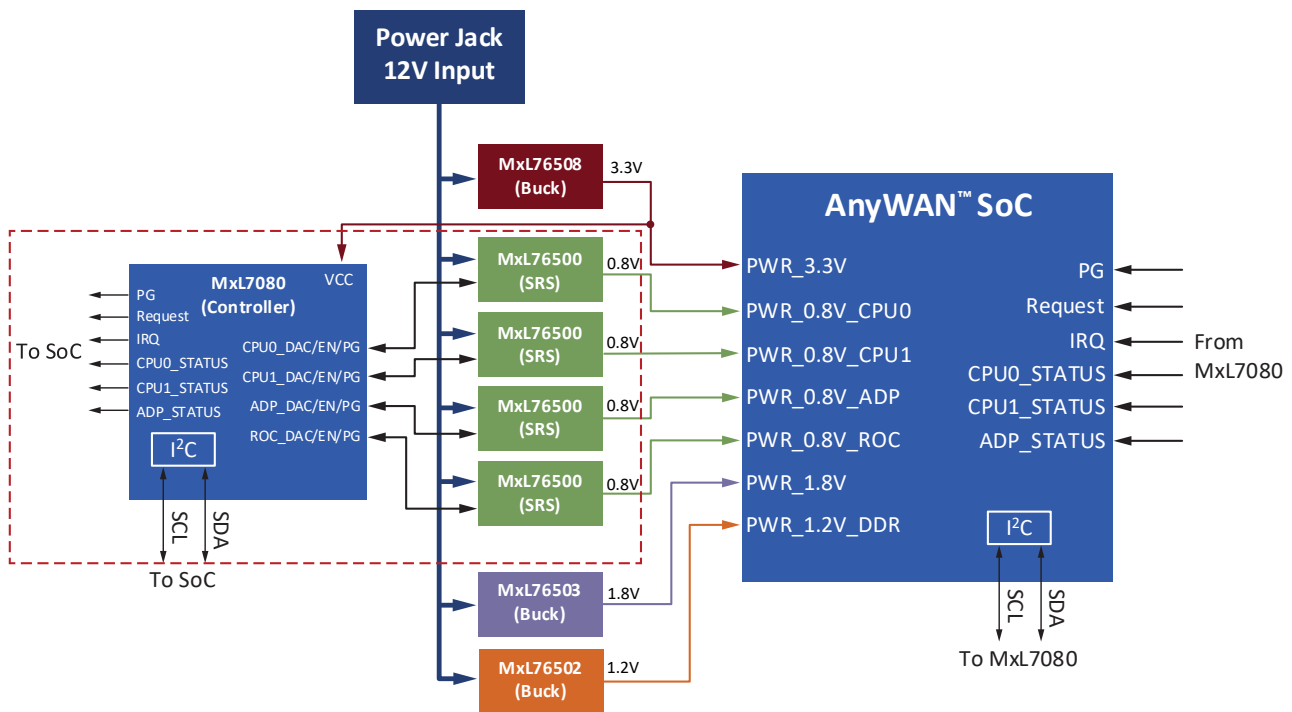

Figure 2: MaxLinear's Comprehensive Power Solution for AnyWAN™ SoC

## Performance Metrics

MaxLinear's architecture differs from traditional monolithic PMICs and offers several advantages:

- Improved thermal performance** under typical and full load. MaxLinear's power solution demonstrates approximately a 25%–30% reduction in junction temperature under full load compared to competitors. While competitors require an additional heatsink due to inefficient thermal design, MaxLinear's solution maintains significantly lower junction temperatures. This thermal efficiency enables reliable operation even in enclosures with minimal or no airflow, eliminates the need for costly heatsinks, and contributes to improved long-term device reliability.

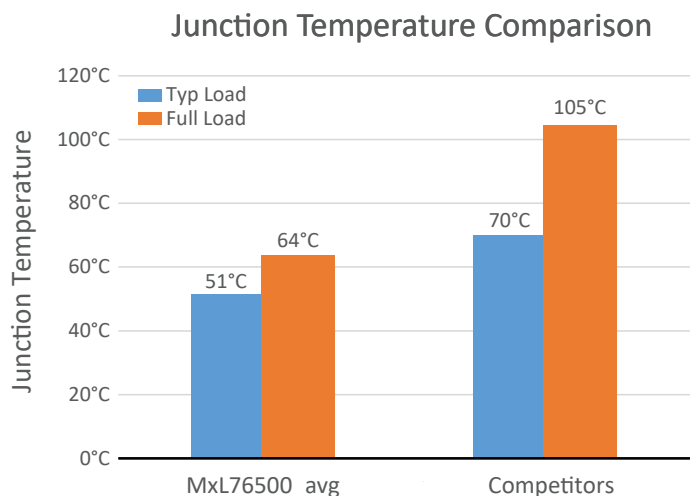

Figure 3: Junction Temperature Comparison under SoC Typical Load and Full Load

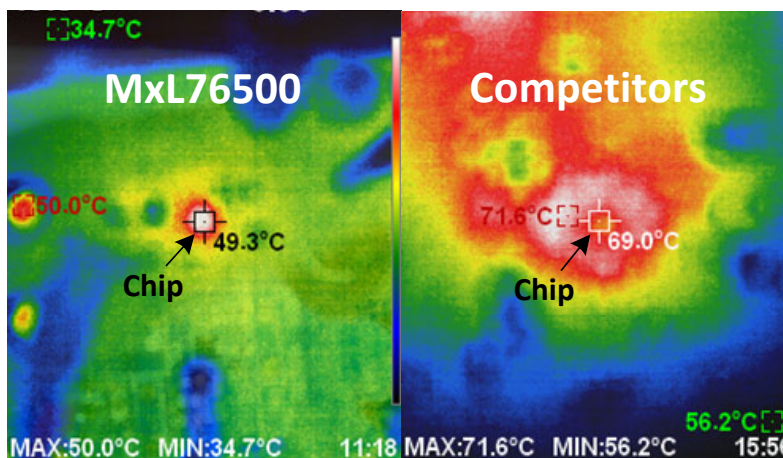

Figure 4: Hotspot Comparison under SoC Typical Load

- Improved system efficiency** is achieved as MxL76500 supports direct 12V input and performs a single-stage conversion to generate the required SoC rail voltages. This streamlined architecture improves overall power efficiency and minimizes conversion losses. Additionally, it eliminates the need for intermediate 5V distribution, reducing power loss due to trace resistance.

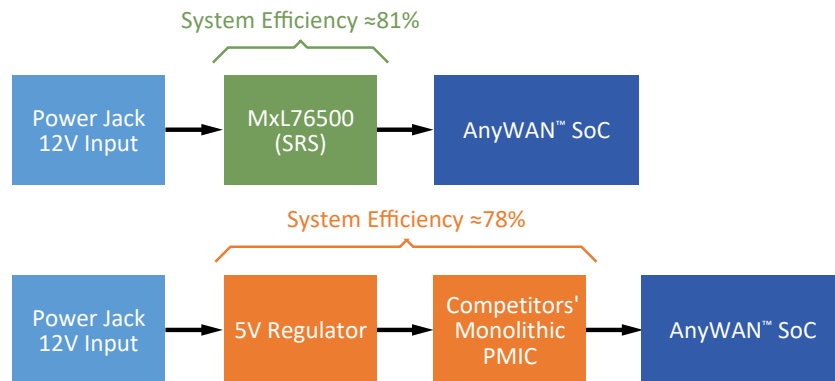

Figure 5: Efficiency Comparison between Single Stage and Two Stages

- Enhanced single-rail efficiency.** MaxLinear's MxL76500 delivers high efficiency from 1.5A to 3.2A, which matches the typical and full-load range of the SoC. In this range, its performance is up to 4% better than that of competitors—making it an ideal choice for the PUMA 8 platform. Although efficiency at light loads is slightly lower, this is not a concern for this application, as the SoC rarely runs below 1.5A. Thanks to reduced heat dissipation, the MxL76500 runs cooler and more efficiently under higher loads, minimizing energy loss and thermal stress.

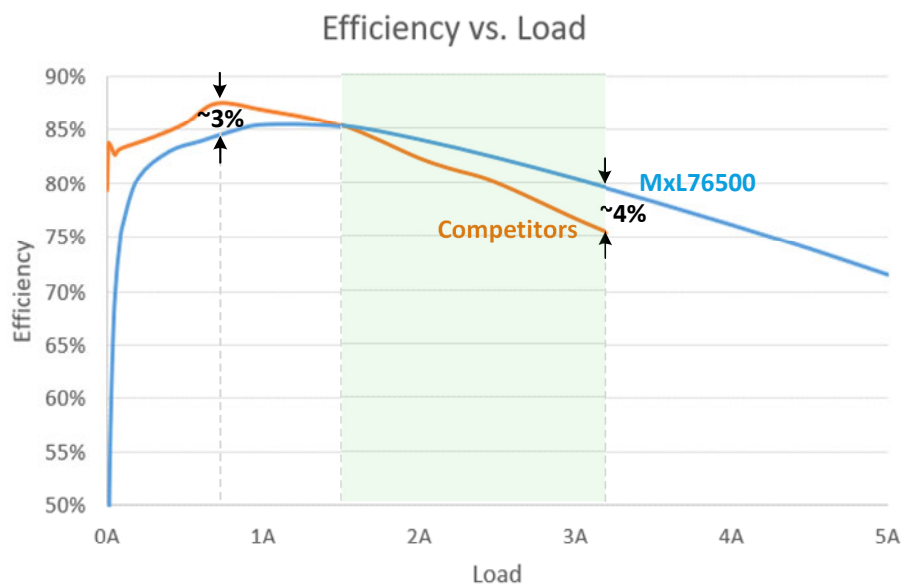

Figure 6: Single-Rail Efficiency Comparison

- **Dynamic voltage scaling (DVS)** with MxL7080 enables real-time voltage adjustments to reduce heat, enhance system stability and longevity, support performance scaling, and improve overall energy efficiency.

#### MxL7080 DVS Highlights

- Supports four outputs
- Voltage range from 0.6V to 1.0V
- Fine control via I<sup>2</sup>C interface with 5mV resolution

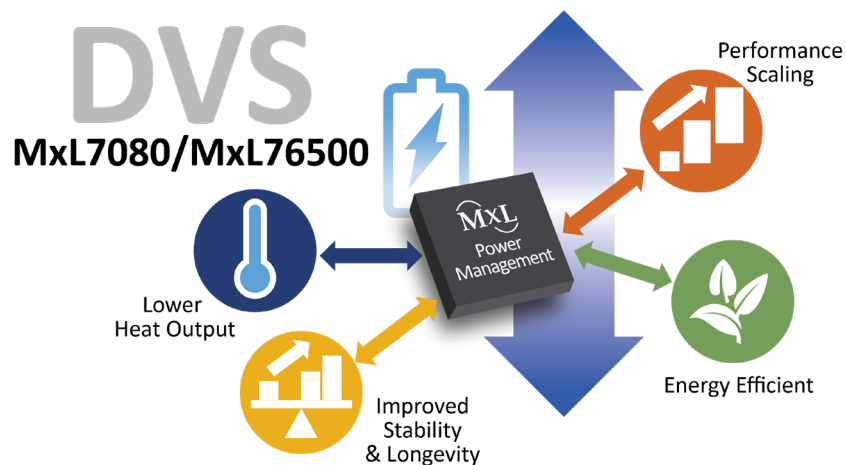

Figure 7: MxL7080/MxL76500 DVS Benefits

The following waveform shows how the output voltage ramps up from 0.6V to 1.0V and then ramps down from 1.0V to 0.6V via the I<sup>2</sup>C interface, allowing the SoC to fine-tune output voltages in real time based on the workload.

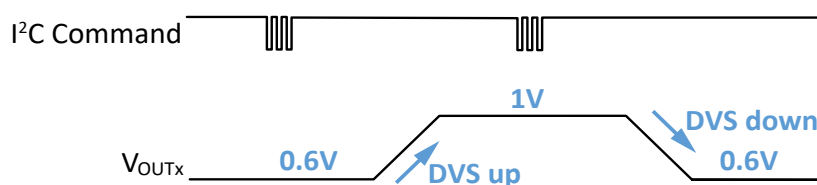

Figure 8: Real-Time Voltage Adjustment Based on Workload Demand

- Selectable power sequencing.** You can configure the power-up and power-down sequence according to the specific requirements of the SoC. A total of 24 sequencing options are available, allowing for flexible customization. The desired power sequence can be pre-programmed at the factory using One-Time Programmable (OTP) memory. The following figure shows two types of power sequencing.

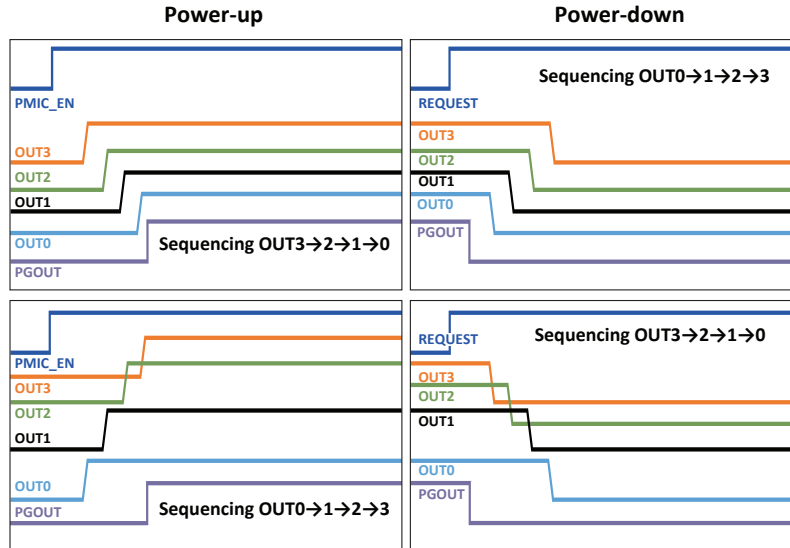

Figure 9: Two Types of Power-Up and Power-Down Sequencing

- Flexible PCB layout,** allowing each power stage to be placed next to the required rails of the SoC, reducing the power loss due to trace resistance. Even if one of the output rails is used by other devices, it can still be placed next to the required rails.

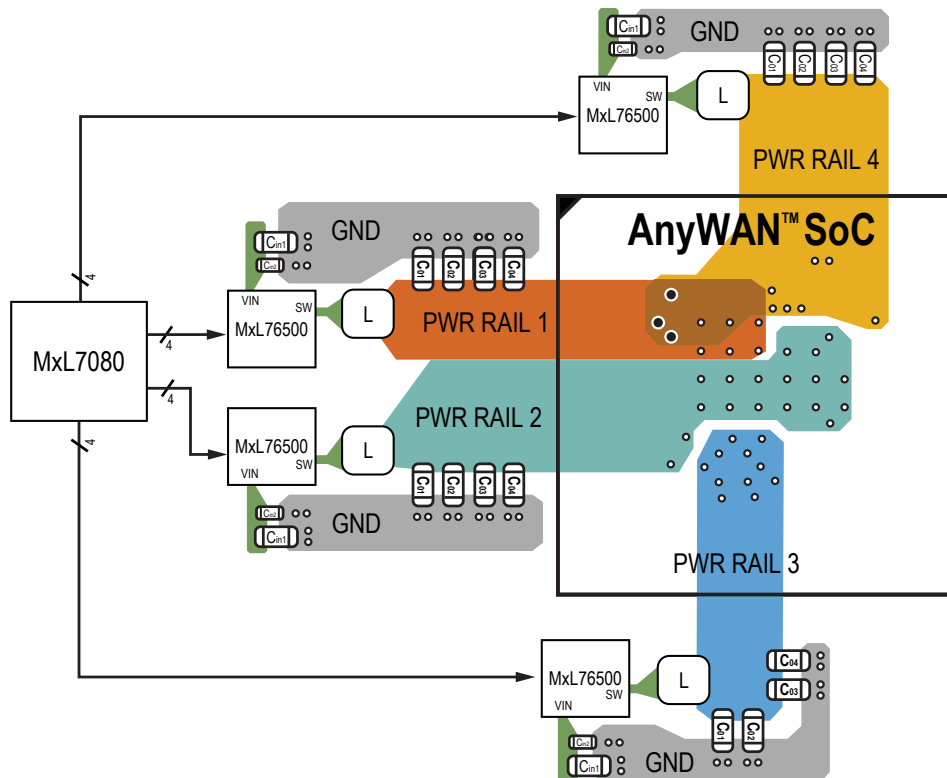

Figure 10: MxL7080/MxL76500-Based Flexible Power Layout for AnyWAN™ SoC

## Advantages over Competitors

Feature	MxL7080 + MxL76500	Competitors
Higher Output Current	Supports up to 5A per rail, satisfying SoC high performance.	Limited to 2–3A per rail.
Wide Input Range	Supports 5V–17V input, ideal for 12V systems.	Limited to 2.85V–5.5V, requiring pre-regulation.
Efficiency	Direct 12V to low-voltage conversion reduces the power loss.	Requires extra conversion stage, reducing efficiency.
Thermal Distribution	Heat is spread across multiple devices, improving thermal performance.	Heat is concentrated in one IC, increasing the thermal stress.
Placement Flexibility	Regulators (SRS) can be placed close to the SoC rails for better efficiency.	All outputs are fixed in one package; longer traces increase losses.
Design Flexibility	Modular architecture allows custom sequencing and layout.	Fixed architecture limits design optimization.
Fault Isolation	Fault in one regulator does not affect others.	Single fault may impact entire PMIC operation.

## Conclusion

MaxLinear's MxL7080 and MxL76500 power solution delivers a reliable, efficient, and flexible approach to powering high-performance SoCs such as AnyWAN™ and PUMA™ 8. Supporting direct 12V input, up to 5A per rail, and a modular layout, it outperforms traditional monolithic PMICs in efficiency, thermal performance, and design versatility. Advanced features such as dynamic voltage scaling and customizable power sequencing enable precise power management and system-level optimization. This solution minimizes power loss, enhances system reliability, and simplifies PCB layout—making it ideal for modern broadband and networking applications.

## References

- *MxL7080 Data Sheet (257DS).*
- *MxL76500 Data Sheet (261DS).*
- *URX85x, MxL256xx Data Sheet.*
- *MxL25640 Hardware Design Guide.*



**MaxLinear, Inc.**  
 5966 La Place Court, Suite 100  
 Carlsbad, CA 92008  
 Tel.: +1 (760) 692-0711  
 Fax: +1 (760) 444-8598  
[www.maxlinear.com](http://www.maxlinear.com)

The content of this document is furnished for informational use only, is subject to change without notice, and should not be construed as a commitment by MaxLinear, Inc. MaxLinear, Inc. assumes no responsibility or liability for any errors or inaccuracies that may appear in the informational content contained in this document.

Reproduction, in part or whole, without the prior written consent of MaxLinear, Inc. is prohibited. MaxLinear, the MaxLinear logo, and any other MaxLinear trademarks (including but not limited to MxL, Full-Spectrum Capture, FSC, AirPHY, Puma, and AnyWAN, VectorBoost, MXL WARE, and Panther) are all property of MaxLinear, Inc. or one of MaxLinear's subsidiaries in the U.S.A. and other countries. All rights reserved. All third-party marks and logos are trademarks™ or registered® trademarks of their respective holders/owners.

© 2025 MaxLinear, Inc. All rights reserved.